

Typical Deck Details

Based on the 2009 Michigan Statewide Building Code

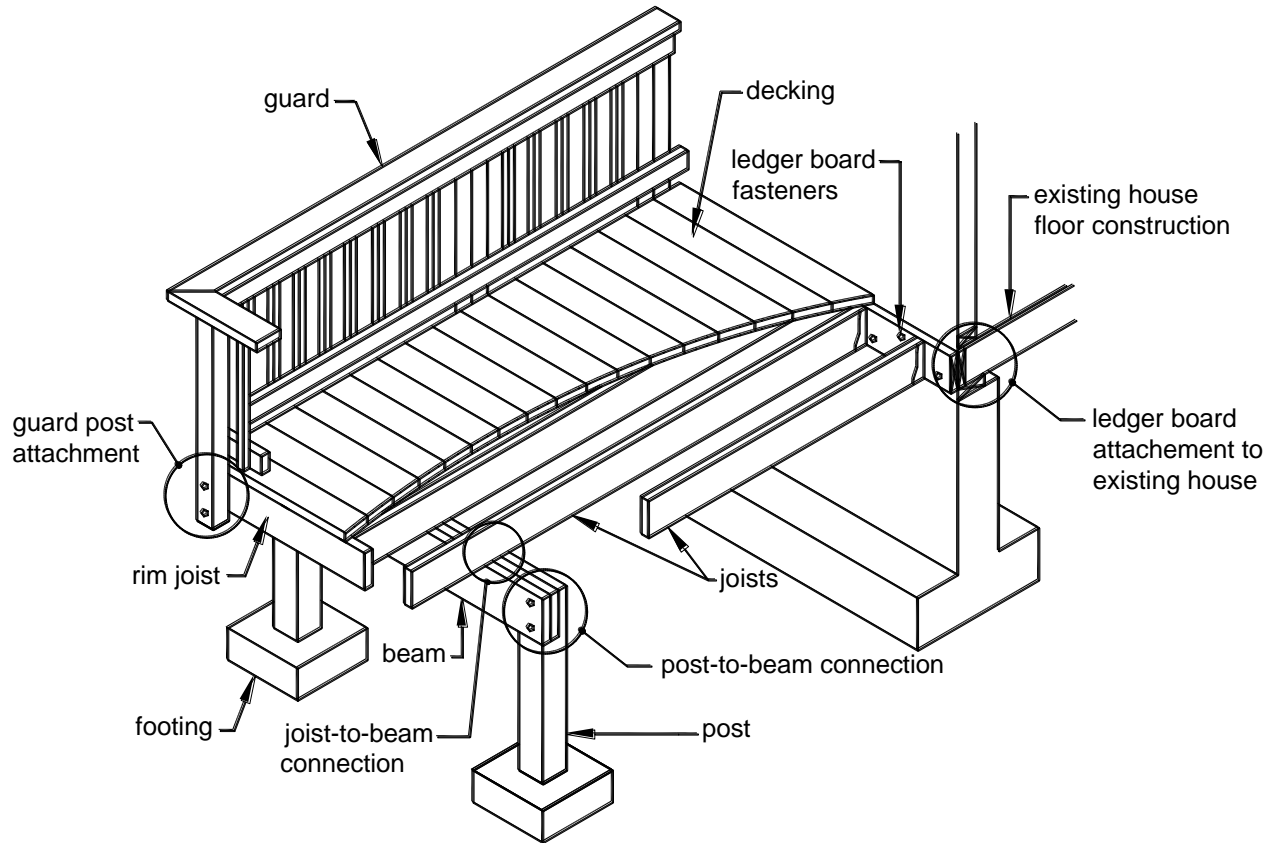

CONTENTS

General Notes.....	2	Ledger Board Fasteners	9
Decking Requirements	2	Free-Standing Decks	11
Joist Size.....	3	Lateral Support of Free-Standing Decks	11
Beam Size & Assembly Requirements	4	Guard Requirements.....	12
Deck Framing Plan	5	Guard Post Attachments.....	13
Joist-to-Beam Connection.....	5	Stair Requirements.....	15
Joist Hangers.....	6	Stair Handrail Requirements	16
Post Requirements	6	Stair Footing Requirements	17
Rim Joist Requirements.....	6	Stair Lighting Requirements	17
Footings.....	7	Framing at Chimney or Bay Window	17
Ledger Attachment Requirements.....	7	Appendices.....	18
Prohibited Ledger Attachments	9	Product Specifications	18

THE USE OF THIS PACKAGE IN LIEU OF SUBMITTED DRAWINGS APPLIES TO SINGLE SPAN, SINGLE LEVEL, RESIDENTIAL DECKS ONLY. DECKS MUST BE CONSTRUCTED IN STRICT CONFORMANCE WITH THE DETAILS CONTAINED HEREIN. A COPY OF THIS DECK DETAIL MUST BE ON THE JOB SITE AND AVAILABLE TO THE INSPECTOR DURING THE INSPECTION PROCESS.

MICHIGAN

Typical Deck Details

Based on the
2009 Michigan Residential Code
decks

GENERAL NOTES

1. All lumber shall be southern pine, grade #2 or better and shall be pressure treated ACQ or CA-B in accordance with American Wood-Preservers' Association standards. All lumber in contact with the ground shall be rated as "ground-contact."
2. All nails shall be spiral or annular grooved.
3. Chemicals used in pressure treatment methods will prematurely corrode standard fasteners, hardware, and flashing when in contact with lumber. To combat corrosion, the following is required.
 - All screws and nails shall be hot-dipped galvanized or stainless steel.
 - All hardware (joist hangers, cast-in-place post anchors, etc.) shall be galvanized with 1.85 oz/sf of zinc (G-185 coating) or shall be stainless steel. Look for products such as "Zmax" from Simpson Strong-Tie or "Triple Zinc" from USP.
4. Decks constructed according to this handout are not approved for future hot tub installations.
5. Deviations from this handout and conditions which do not meet the details shown herein require a plan submission.
6. Inspections:
 - A footing, framing, and final inspection, is required on all decks.
 - Footing inspections are required PRIOR to the placement of concrete.
 - Framing and final inspections may be combined if all portions of the deck framing and mechanical attachments are at least 42" above grade.
 - Inspections are required by law. Failure to receive any and all inspections can result in the issuance of violations which may lead to legal proceedings.
7. It is the responsibility of the permit holder or the permit holder's representative to notify the authority when the stages of construction are reached that require an inspection. Inspection requests may be made using one of the three methods listed below; please have your permit number available when scheduling an inspection.
8. Decks shall not be used or occupied until a final inspection approval is obtained.

DECKING REQUIREMENTS

All decking material shall be composed of 2x6 or 5/4 ("five-quarter") board. Attach decking to each joist with 2-8d nails or 2-#8 screws. See FIGURE 10 for decking connection requirements at the rim joist. Decking may be placed from an angle perpendicular to the joists to an angle of 45 degrees to the joists. Each piece of decking must bear on a minimum of 4 joists.

Decking composed of foreign lumber, plastic or manufactured materials may be substituted only when the product has an approved evaluation report from an accredited testing laboratory which has listed the product. For a list of approved products, go to the website below.

The evaluation report must be on the jobsite and available to the inspector during the inspection process. Installation and span lengths of the substituted material must be in strict conformance with the evaluation report and the manufacturer's instructions. All decking products must be capable of supporting a live load of 40 pounds per square feet.

MICHIGAN

Typical Deck Details

Based on the
2009 Michigan Residential Code
decks

JOIST SIZE

The span of a joist is measured from the centerline of bearing at one end of the joist to the centerline of bearing at the other and does not include the length of the overhangs. Use TABLE 1 to determine your joist span based on lumber size and joist spacing. See FIGURE 1 and FIGURE 2 for joist span types.

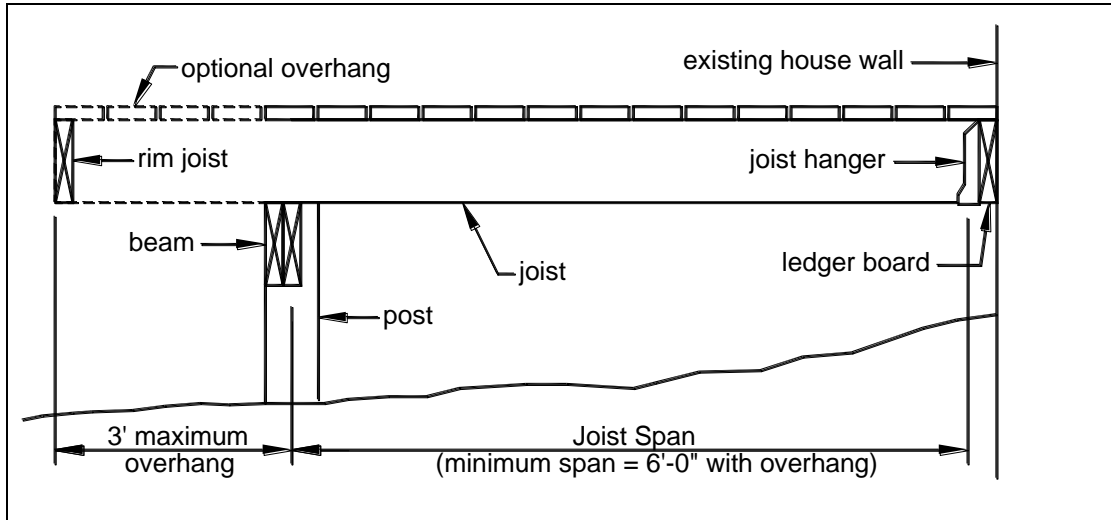

FIGURE 1: JOIST SPAN - DECK ATTACHED AT HOUSE

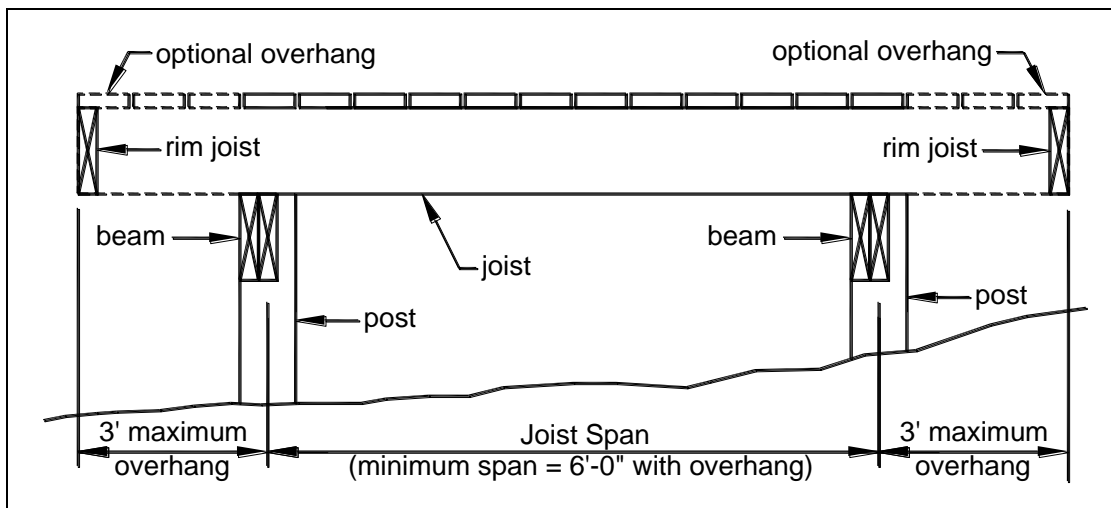

FIGURE 2: JOIST SPAN - FREE-STANDING DECK

TABLE 1: MAXIMUM JOIST SPANS

Joist Size	Joist Spacing, on center	Joist Span ¹ excludes overhangs
2x6	16"	9'-5"
2x6	24"	7'-10"
2x8	16"	12'-10"
2x8	24"	10'-2"
2x10	16"	15'-2"
2x10	24"	13'-1"
2x12	16"	18'-0"
2x12	24"	15'-5"

¹ Spans based on 40 PSF live load, 10 PSF dead load, southern pine#2, normal loading duration, wet service conditions and deflection: $\Delta = l/360$.

MICHIGAN

Typical Deck Details

Based on the
2009 Michigan Residential Code
decks

BEAM SIZE & ASSEMBLY REQUIREMENTS

The determination of beam size is based on your joist span characteristics. Use TABLE 2 if your joists do not overhang or TABLE 3 if your joists overhang. See FIGURE 3 for beam span types.

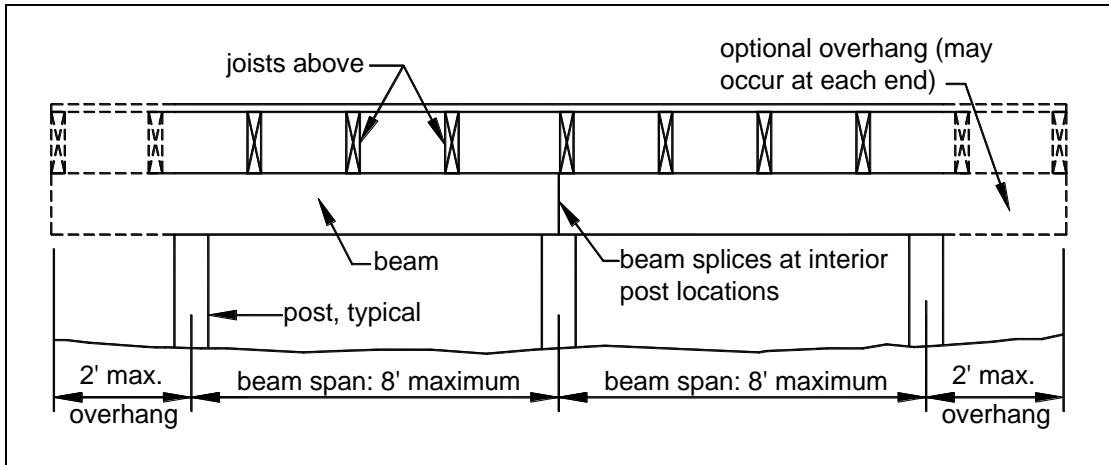

FIGURE 3: BEAM SPAN TYPES

Joists may bear atop the beam, as shown in FIGURE 3 above, and extend past the beam centerline up to 3'-0", as shown in FIGURE 2 and FIGURE 3, or the joists may attach to the side of the beam with joist hangers. See JOIST-TO-BEAM CONNECTION details, FIGURE 6 on Sheet 5.

TABLE 2: MINIMUM BEAM SIZE WHEN JOISTS HAVE NO OVERHANGS

Joist Span	Beam Size
0 - 6'-8"	(2) 2x6*
6'-9" - 11'-2"	(2) 2x8*
11'-3" - 16'-0"	(2) 2x10*
16'-1" - 18'-0"	(2) 2x12

TABLE 3: MINIMUM BEAM SIZE WHEN JOISTS OVERHANG

Joist Span	Beam Size
0 - 6'-0"	(2) 2x8*
6'-1" - 12'-8"	(2) 2x10*
12'-9" - 18'-0"	(2) 2x12

* You may substitute a larger beam size for the one shown in the table. For instance, if the table requires (2) 2x8, you may substitute a (2) 2x10 or (2) 2x12.

The deck's beam is assembled by attaching the two members identified in the tables above in accordance with FIGURE 4.

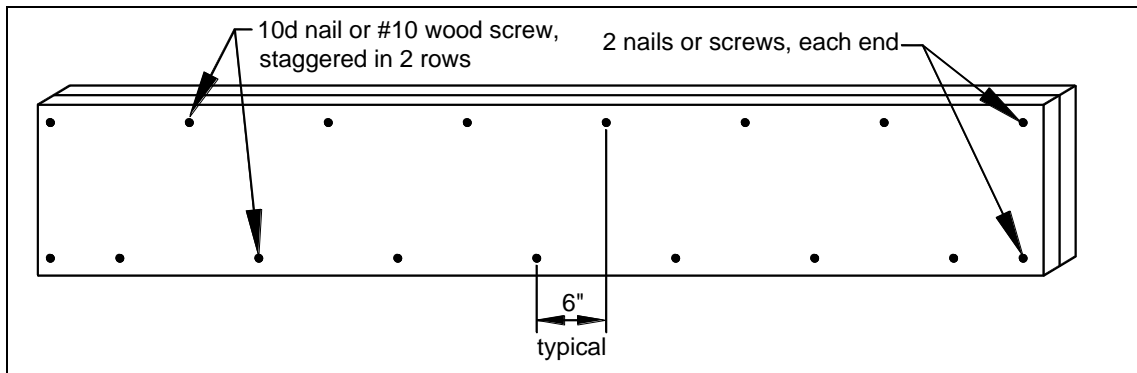

FIGURE 4: BEAM ASSEMBLY DETAIL

MICHIGAN

Typical Deck Details

Based on the
2009 Michigan Residential Code
decks

DECK FRAMING PLAN

A framing plan shows a bird's-eye view of the joist and beam layout; the location of the ledger board, posts and footings, and the type, size and spacing of the ledger board fasteners. See FIGURE 5 for an example of a typical deck framing plan.

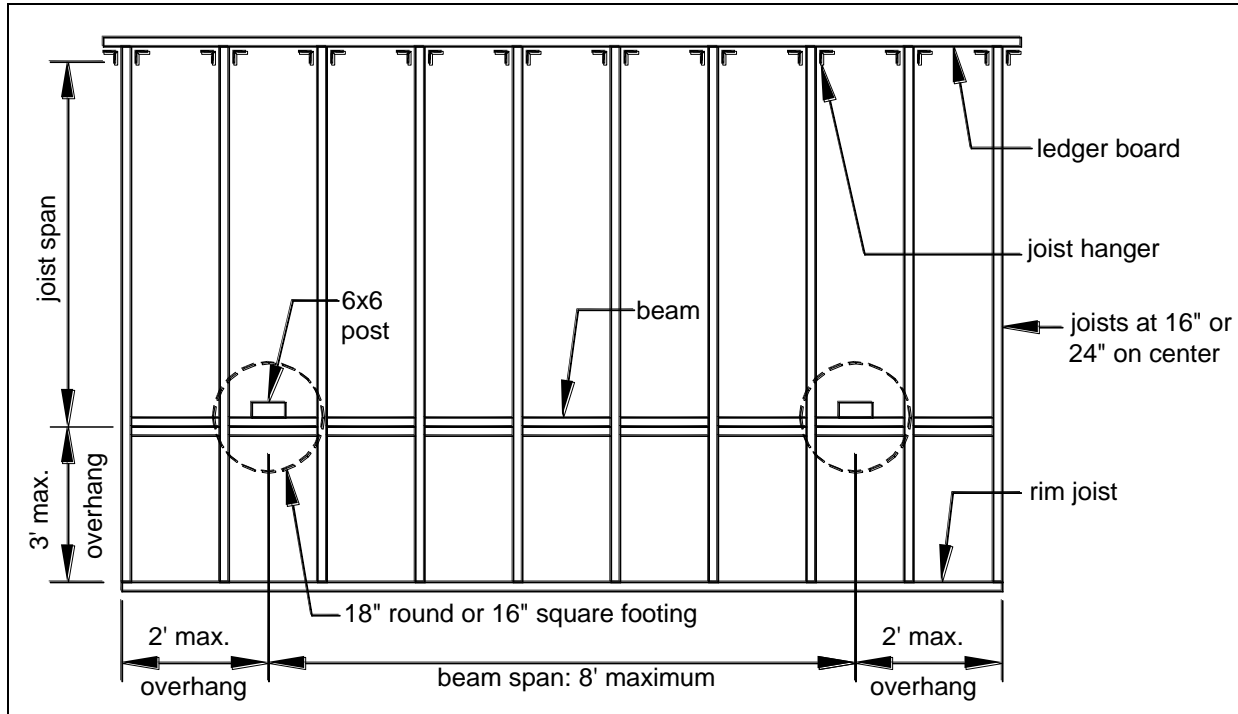

FIGURE 5: TYPICAL DECK FRAMING PLAN

JOIST-TO-BEAM CONNECTION

Each joist shall be attached to the beam as shown in FIGURE 6. Joists may bear on and overhang past the beam a maximum of 3'-0". Use Option 1 or Option 2 to attach the joist to the beam. Joists may also attach to the side of the beam with joist hangers. See JOIST HANGERS on Sheet 6 for more information. Hangers, clips and mechanical fasteners shall be galvanized with 1.85 oz/sf of zinc (G-185 coating) or shall be stainless steel.

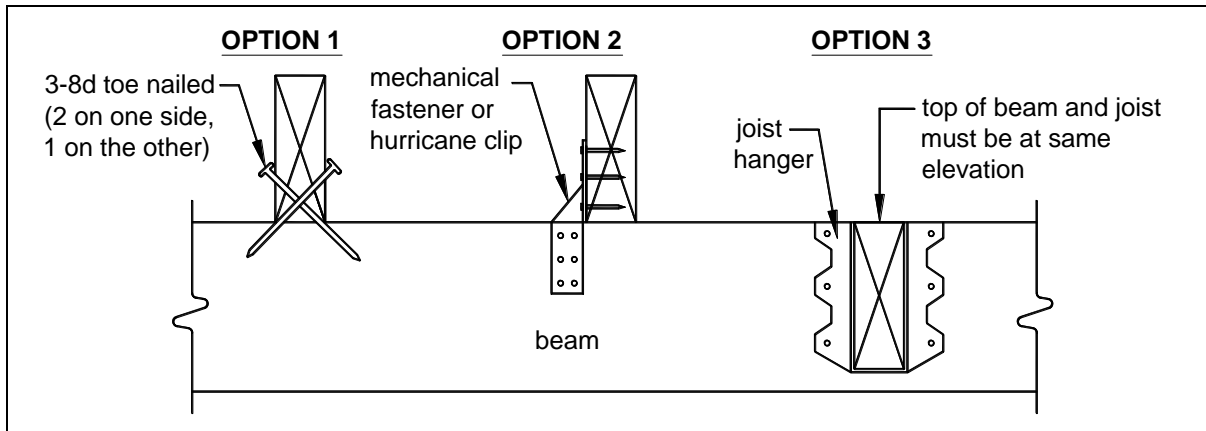

FIGURE 6: JOIST-TO-BEAM DETAIL

MICHIGAN

Typical Deck Details

Based on the
2009 Michigan Residential Code
decks

JOIST HANGERS

Joist hangers, as shown in FIGURE 7, shall each have a minimum capacity of 1000 lbs. The depth and width of the joist hanger shall equal the dimensions of the joist or header it is carrying. Joist hangers shall be galvanized with 1.85 oz/sf of zinc (G-185 coating) or stainless steel.

Use joist hangers with inside flanges when clearances to the edge of the beam or ledger board dictate. **Do not use clip angles or brackets to support framing members.**

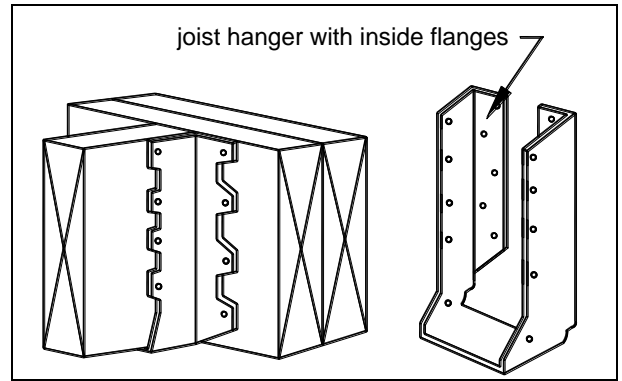

FIGURE 7: TYPICAL JOIST HANGERS

POST REQUIREMENTS

All deck post sizes shall be 6x6, and the maximum height shall be 14'-0". The beam shall be attached to the post by notching the 6x6 as shown in FIGURE 8. All thru-bolts shall have washers at the bolt head and nut. Attachment of the beam to the side of the post without notching is prohibited; see FIGURE 9.

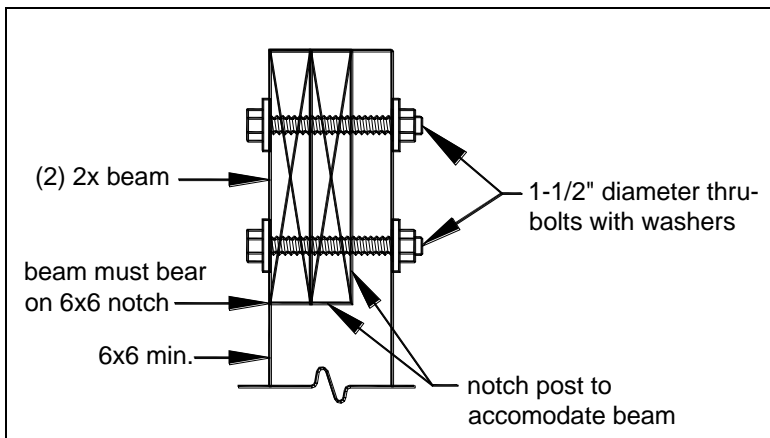

FIGURE 8: POST-TO-BEAM REQUIREMENTS

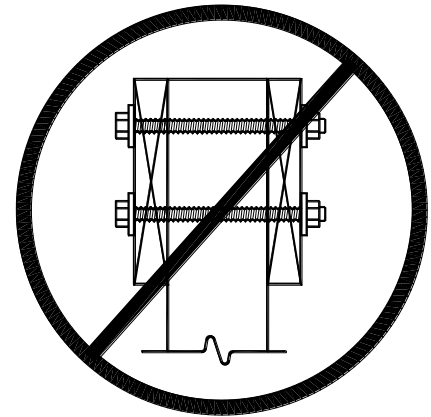

FIGURE 9: PROHIBITED POST-TO-BEAM ATTACHMENT CONDITION

RIM JOIST REQUIREMENTS

Attach a continuous rim joist to the ends of joists as shown in FIGURE 10. Attach decking to the rim joist as shown in FIGURE 10. For more decking attachment requirements, see DECKING REQUIREMENTS on Sheet 2.

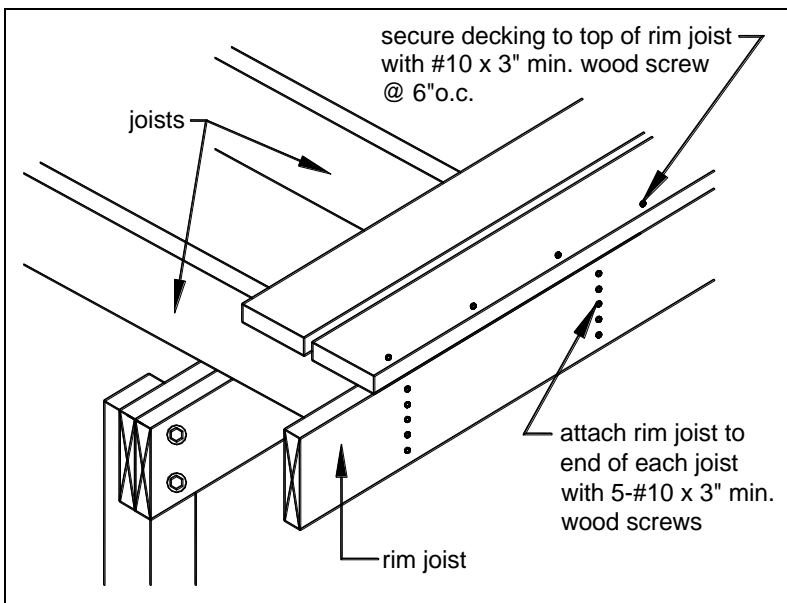

FIGURE 10: RIM JOIST CONNECTION DETAILS

MICHIGAN

Typical Deck Details

Based on the
2009 Michigan Residential Code
decks

FOOTINGS

See FIGURE 11 for footing size, footing thickness and post attachment options and requirements. All footings shall bear on solid ground; bearing conditions shall be verified in the field by county inspectors prior to placement of concrete. DECK FOOTINGS CLOSER THAN 5'-0" TO AN EXISTING EXTERIOR HOUSE WALL MUST BEAR AT THE SAME ELEVATION AS THE FOOTING OF THE EXISTING HOUSE FOUNDATION.

Do not construct footings over utility lines or enclosed meters. Call Miss dig Utility at 1-800-482-7171 before you dig.

Pre-manufactured post anchors shall be galvanized with 1.85 oz/sf of zinc (G-185 coating) or shall be stainless steel.

Note: Minimum depth of footing is to be 42 inches deep not 24

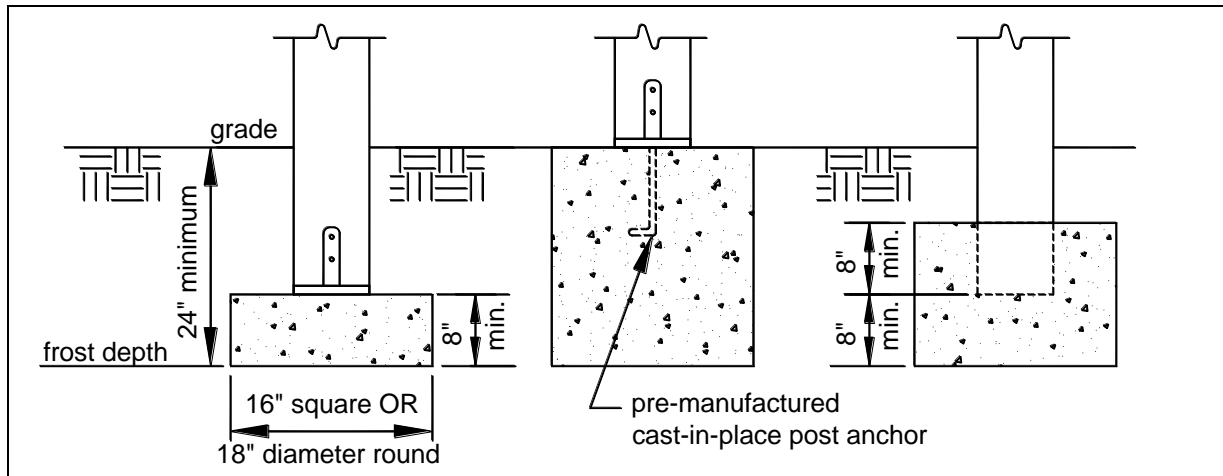

FIGURE 11: TYPICAL FOOTING DETAILS

LEDGER ATTACHMENT REQUIREMENTS

GENERAL: Attach the ledger board, which shall be equal to or greater than the joists size, to the existing exterior wall in accordance with FIGURE 13 through FIGURE 15. When attachments are made to the existing house band board, the band board shall be capable of supporting the new deck. If this cannot be verified or conditions at the existing house differ from the details herein, then a free-standing deck is required. See FREE-STANDING DECKS on Sheet 11.

YOU MUST VERIFY THE EXISTING CONDITIONS IN THE FIELD PRIOR TO APPLYING FOR A BUILDING PERMIT. COMPLIANCE WITH ALL THE REQUIREMENTS HEREIN IS CRITICAL TO ENSURE THE STRUCTURAL STABILITY OF YOUR DECK AND THE SAFETY OF YOU AND YOUR FAMILY.

SIDING AND FLASHING: House siding, or the exterior finish system, must be removed prior to the installation of the ledger board. Flashing is required at any ledger board connection to a wall of wood framed construction and shall be composed of copper (attached using copper nails), stainless steel, UV resistant plastic or galvanized steel coated with 1.85 oz/sf of zinc (G-185 coating). See FIGURE 13 for continuous flashing with drip edge.

MANUFACTURED WOOD JOIST: The term "MWJ" denotes manufactured wood "I" joists; see FIGURE 12. Examples of manufactured wood joists are TJI, GPI, and LPI.

Many new homes constructed with MWJs include a 1-¹/₄" manufactured solid band board that can support the attachment of a deck; see FIGURE 13. However, older homes constructed with MWJs may only include a plywood band board which cannot support a deck. In such cases a free-standing deck or a full plan submission is required.

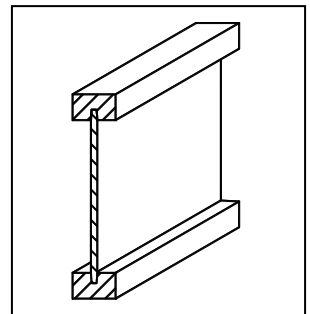

FIGURE 12: MWJ PROFILE

MI

Typical Deck Details

Based on the
2009 Michigan Residential Code
decks

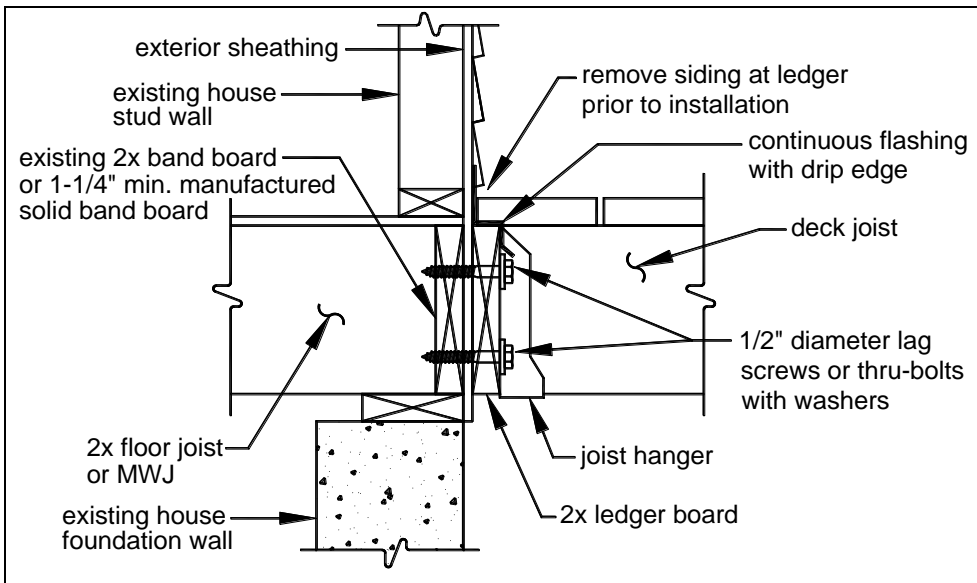

FIGURE 13: ATTACHMENT OF LEDGER BOARD-TO-BAND BOARD

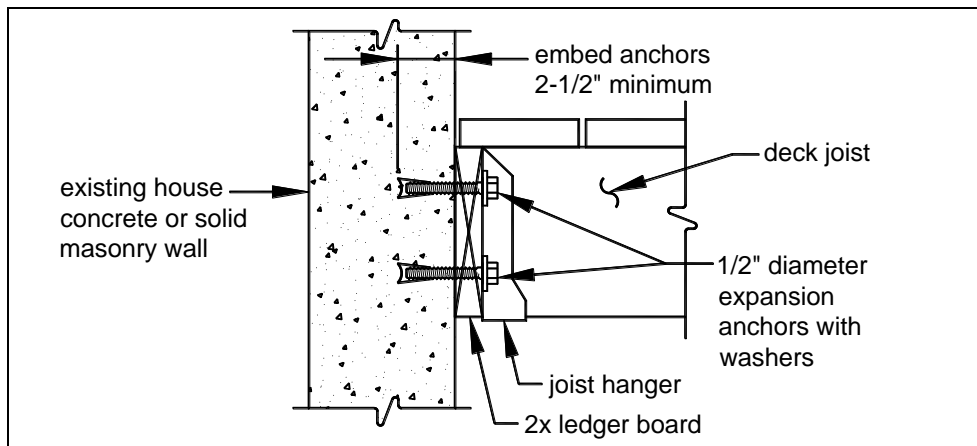

FIGURE 14: ATTACHMENT OF LEDGER BOARD-TO-FOUNDATION WALL (CONCRETE OR SOLID MASONRY)

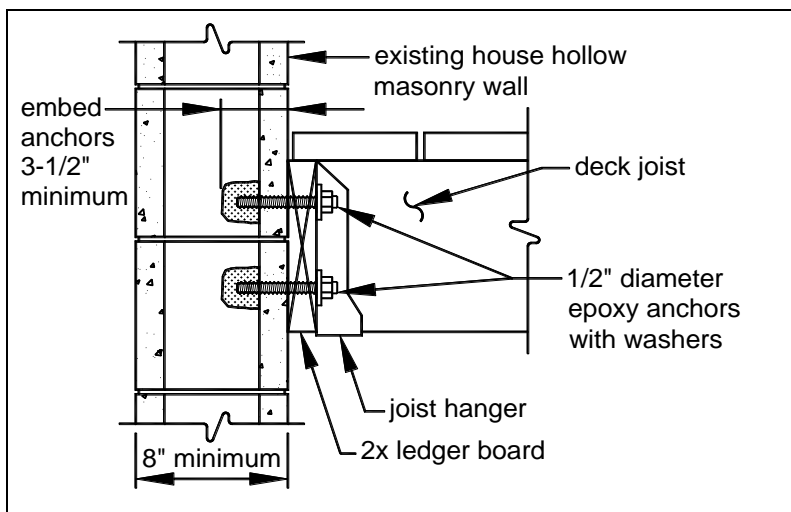

FIGURE 15: ATTACHMENT OF LEDGER BOARD-TO-FOUNDATION WALL (HOLLOW MASONRY)

MICHIGAN

Typical Deck Details

Based on the
2009 Michigan Residential Code
decks

PROHIBITED LEDGER ATTACHMENTS

Attachments to the ends of pre-manufactured open web joists, to brick veneers, and to house overhangs or bay windows are strictly prohibited; see FIGURE 16 through FIGURE 18. In such cases the deck shall be free-standing. See FREE-STANDING DECKS on Sheet 11.

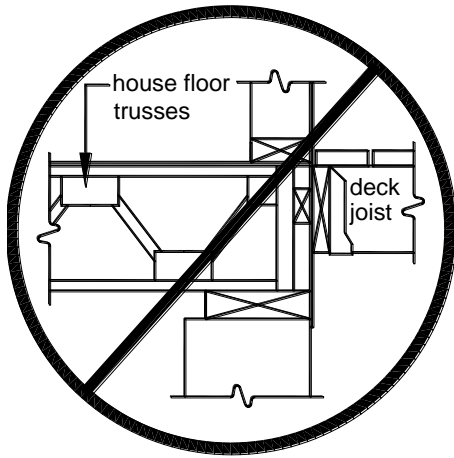

FIGURE 16: NO ATTACHMENT TO OPEN WEB TRUSSES

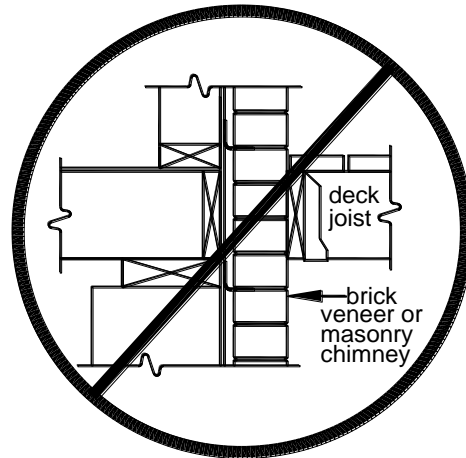

FIGURE 17: NO ATTACHMENT TO OR THRU BRICK VENEER

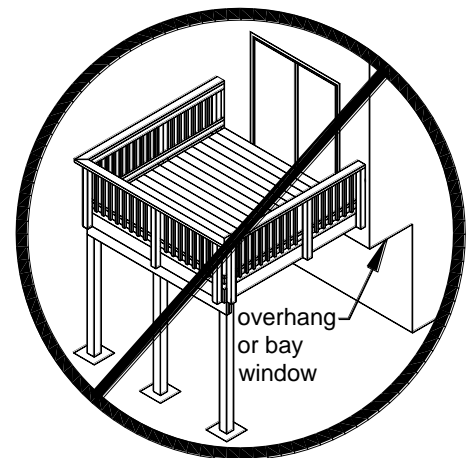

FIGURE 18: NO ATTACHMENT TO HOUSE OVERHANG

LEDGER BOARD FASTENERS

The spacing between ledger board fasteners is dependent on the span length of the joists. Use TABLE 4 to determine fastener spacing and install in the configuration shown in FIGURE 19. All fasteners shall be installed with washers and must be thoroughly tightened. Adequacy of connections will be verified by county inspectors. If a ladder is required to access the ledger board, one must be provided by the property owner, permit holder, or their representative.

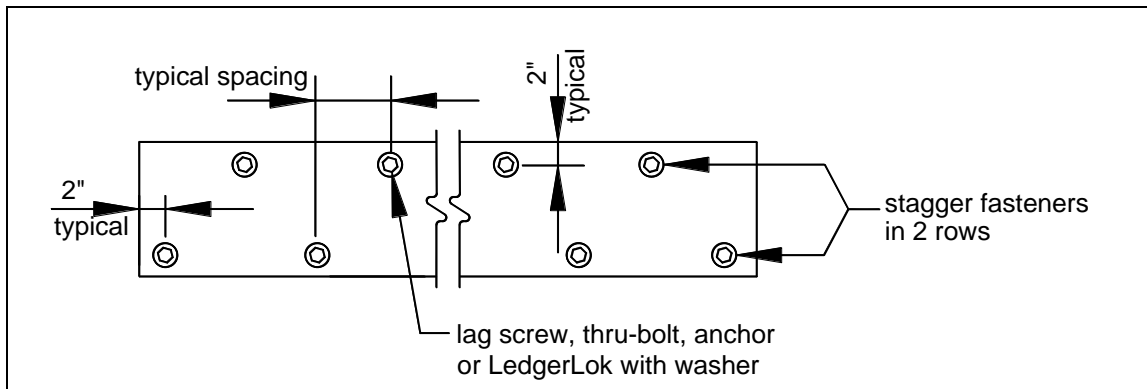

FIGURE 19: LEDGER BOARD FASTENER SPACING AND CLEARANCES

TABLE 4: LEDGER BOARD FASTENER SPACING

Joist Span	Fastener spacing, on center		
	Lag Screws*	LedgerLok*	Thru-bolts, Expansion Anchors, Epoxy Anchors*
0 – 6'-0"	30"	16"	36"
6'-1" – 8'-0"	23"	12"	36"
8'-1" – 10'-0"	18"	10"	34"
10'-1" – 12'-0"	15"	8"	29"
12'-1" – 14'-0"	13"	7"	24"
14'-1" – 16'-0"	11"	6"	21"
16'-1" – 18'-0"	10"	5"	19"

*See Sheet 10 for fastener specifications.

MICHIGAN

Typical Deck Details

Based on the
2009 Michigan Residential Code
decks

Thru-Bolts

Thru-bolts shall have a minimum diameter of $\frac{1}{2}$ ". Pilot holes for thru-bolts shall be $\frac{17}{32}$ " to $\frac{9}{16}$ " in diameter. Thru-bolts must be equipped with washers at the bolt head and nut.

Expansion Anchors

Use expansion anchors when attaching a ledger board to a concrete or solid masonry wall as shown in FIGURE 14. Bolt diameters of the anchors shall be a minimum of $\frac{1}{2}$ "; in some cases, this may require an anchor size of $\frac{5}{8}$ ". Minimum embedment length shall be $2\text{-}\frac{1}{2}$ ". Expansion anchors must have washers.

Epoxy Anchors

When attaching to hollow masonry, fill the cells with grout and use expansion anchors, or use one of the approved epoxy anchors listed in TABLE 5 and install as shown in FIGURE 15. Epoxy anchors shall have a minimum diameter of $\frac{1}{2}$ " and minimum embedment length of $3\text{-}\frac{1}{2}$ ". Installation shall be in strict conformance to the manufacturer's instructions. Epoxy anchors must have washers.

TABLE 5: APPROVED EPOXY ANCHORS

Manufacturer	Product
ITW Ramset/Red Head	Epcon Acrylic 7
Hilti	HY-20

Lag Screws

Lag screws shall have a minimum diameter of $\frac{1}{2}$ " and shall be hot-dipped galvanized or stainless steel. Lag screws may be used only when the field conditions match those shown in FIGURE 13. **You must verify the existing conditions in the field prior to applying for a building permit and installing lag screws. Compliance with all the requirements herein is critical to ensure the structural stability of your deck.** See FIGURE 20 for lag screw length and shank requirements. All lag screws shall be installed with washers.

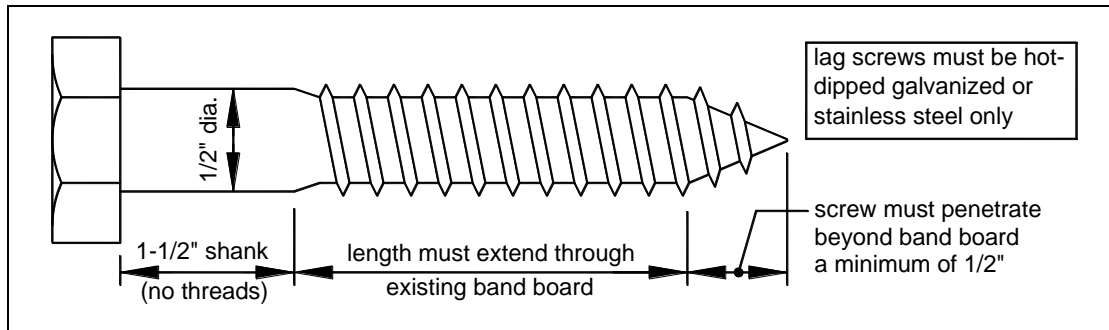

FIGURE 20: LAG SCREW REQUIREMENTS

Lag screw installation requirements: Each lag screw shall have pilot holes drilled as follows: 1) Drill a $\frac{1}{2}$ " diameter hole in the ledger board, 2) Drill a $\frac{5}{16}$ " diameter hole into the solid connection material of the existing house. **DO NOT DRILL A $\frac{1}{2}$ " DIAMETER HOLE INTO THE SOLID CONNECTION MATERIAL.**

The threaded portion of the lag screw shall be inserted into the pilot hole by turning. **DO NOT DRIVE WITH A HAMMER.** Use soap or a wood-compatible lubricant as required to facilitate tightening. Each lag screw shall be thoroughly tightened.

LedgerLok

LedgerLok by FastenMaster, a proprietary fastener listed by ICC-ES, is similar to a lag screw. LedgerLoks have a diameter less than $\frac{1}{4}$ " and an integrated washer. No pilot hole is required for installation. LedgerLoks shall be of sufficient length to fully penetrate the existing house band board and shall be installed in strict conformance with the manufacturer's instructions.

MICHIGAN

Typical Deck Details

Based on the
2009 Michigan Residential Code
decks

FREE-STANDING DECKS

Decks which are free-standing do not utilize the exterior wall of the existing house to support vertical loads; instead, an additional beam with posts is provided at or within 3'-0" of the existing house. THE ASSOCIATED DECK POST FOOTINGS SHALL BE PLACED AT THE SAME ELEVATION AS THE EXISTING HOUSE FOOTING. See FIGURE 2 and FIGURE 21. Beam size is determined by TABLE 2 or TABLE 3.

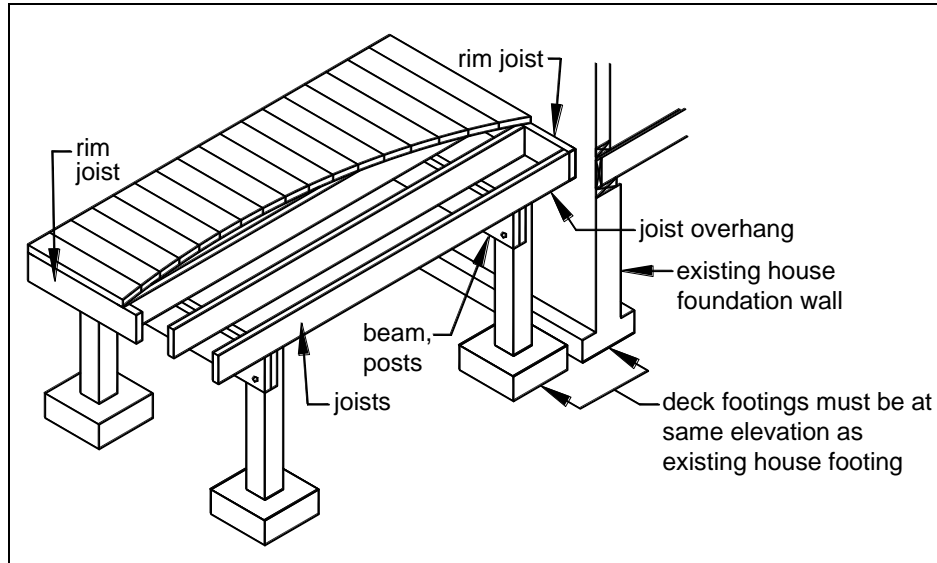

FIGURE 21: FREE-STANDING DECK

LATERAL SUPPORT OF FREE-STANDING DECKS

Free standing decks greater than 2 feet above grade shall resist lateral loading and horizontal movement by providing diagonal bracing or by attaching to the exterior wall of the house.

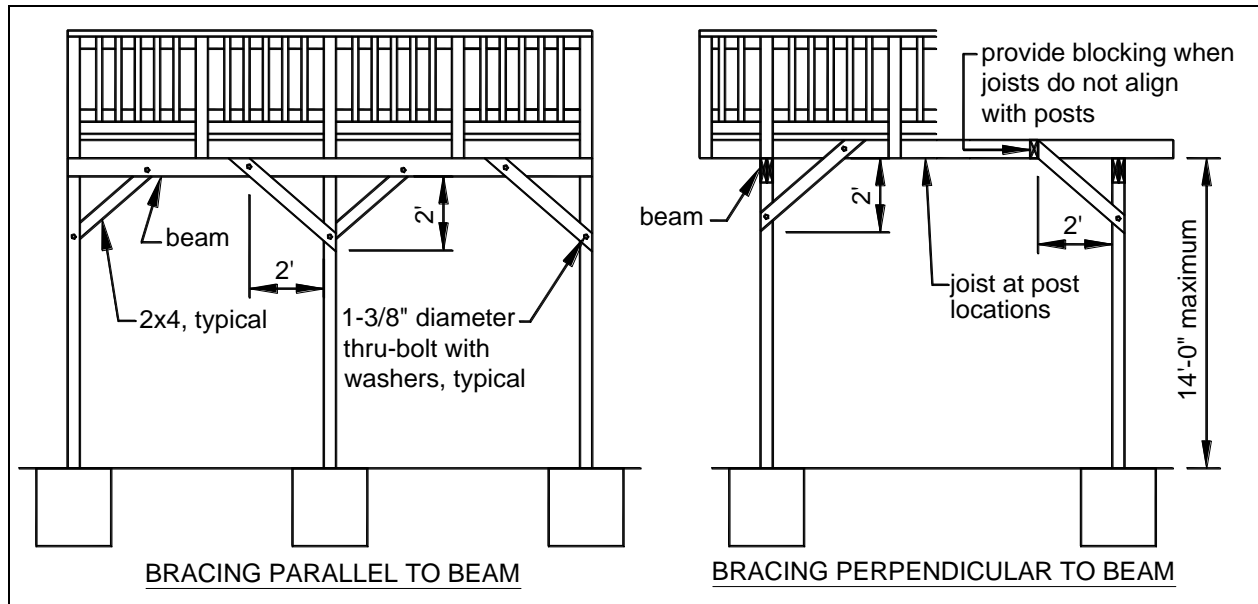

FIGURE 22: DIAGONAL BRACING REQUIREMENTS

Diagonal Bracing: Provide diagonal bracing both parallel and perpendicular to the beam at each post as shown in FIGURE 22. When parallel to the beam, the bracing shall be bolted to the post at one end and beam at the other. When perpendicular to the beam, the bracing shall be bolted to the post at one end and a joist at the other. When a joist does not align with the bracing location, provide blocking between the next adjacent joists.

MICHIGAN

Typical Deck Details

Based on the
2009 Michigan Residential Code
decks

Attachment to House: Attach the deck rim joist to the existing house exterior wall as shown in **FIGURE 23**. The wall must be sheathed with a minimum $\frac{3}{8}$ " structural panel sheathing. Use lag screws or thru-bolts when fastening to an existing band board or wall stud; use expansion anchors or epoxy anchors when fastening to concrete or masonry. **DO NOT ATTACH TO BRICK VENEERS. YOU MUST VERIFY THIS CONDITION IN THE FIELD PRIOR TO UTILIZING THIS METHOD.** Fasteners shall be 16" on center and staggered in 2 rows. Flashing over the rim joist is required and must be installed in accordance with the flashing provisions on Sheet 7.

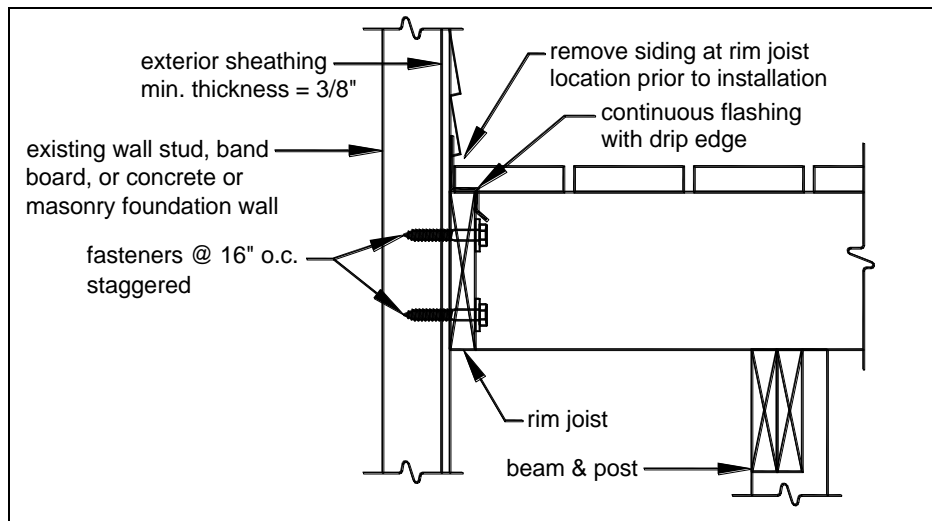

FIGURE 23: ATTACHMENT TO HOUSE LATERAL SUPPORT

GUARD REQUIREMENTS

All decks greater than 30" above grade are required to have a guard. If you are providing a guard when one is not required, it must meet these requirements. All guards shall be constructed in strict conformance with details herein; any deviations require a plan submission.

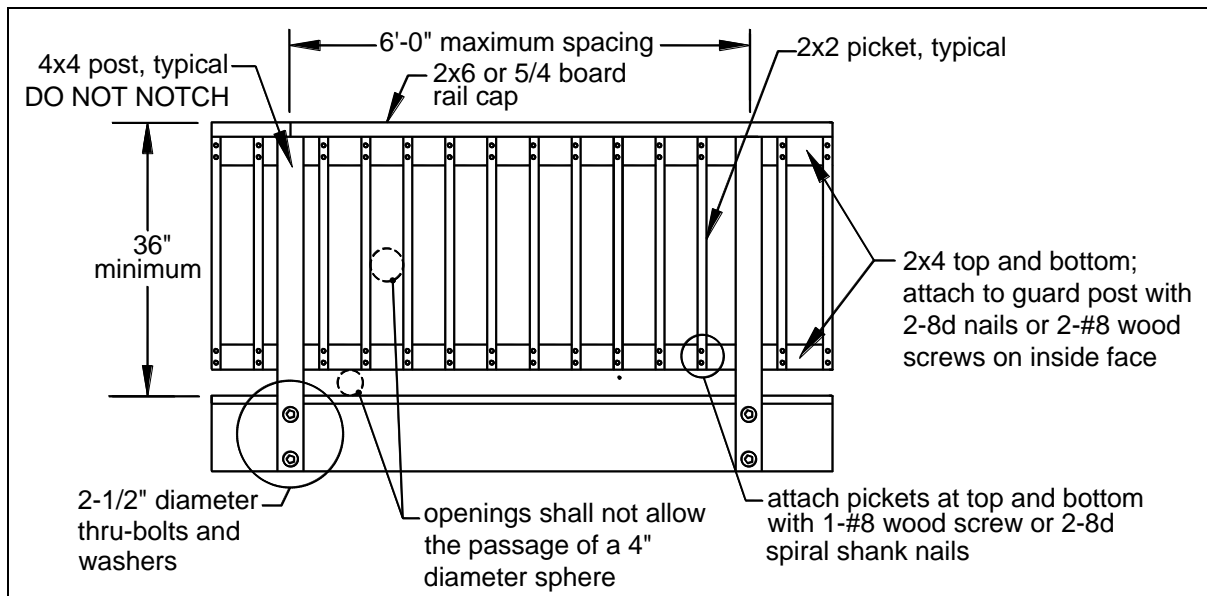

FIGURE 24: TYPICAL GUARD DETAIL

Any pre-fabricated wood, plastic, composite or manufactured guard system purchased from a home center store, lumber company or similar will also require a plan submission.

ONLY THOSE PLASTIC, COMPOSITE OR MANUFACTURED GUARD SYSTEMS LISTED BY AN ACCREDITED TESTING AGENCY ARE APPROVED FOR USE.

MICHIGAN

Typical Deck Details

Based on the
2009 Michigan Residential Code
decks

GUARD POST ATTACHMENTS

GUARD POST TO OUTSIDE-JOIST: Guard posts for guards which run parallel to the deck joists (side of deck) shall be attached to the outside-joist per FIGURE 25.

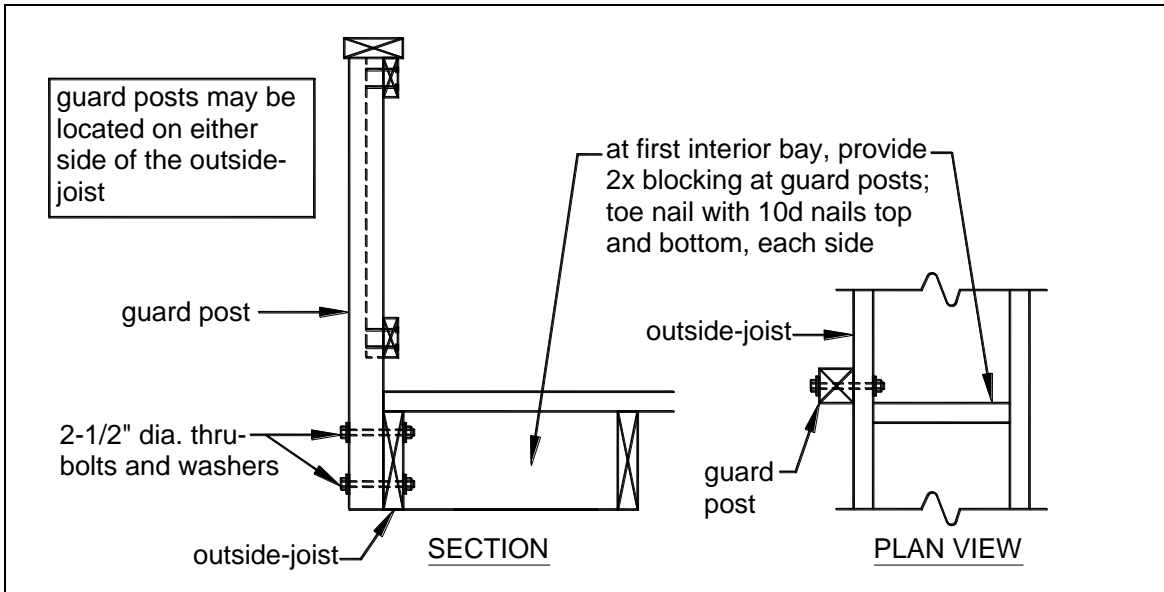

FIGURE 25: GUARD POST TO OUTSIDE JOIST DETAIL

GUARD POST TO RIM JOIST: Use one of the options shown in FIGURE 26 through FIGURE 28 to attach a guard post to a rim joist. See FIGURE 10 for rim joist-to-deck joist and decking-to-rim joist attachment requirements.

OPTION 1: As shown in FIGURE 26, guard posts are attached to the inside face of the rim joists. To attach guard post to the outside of the rim joist, see OPTION 2 or OPTION 3.

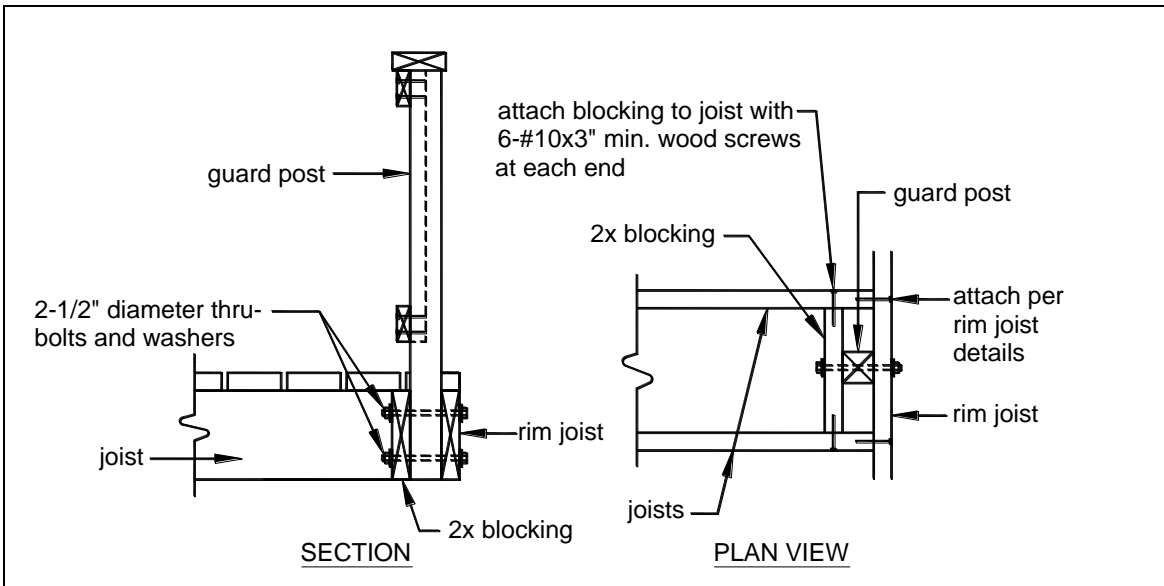

FIGURE 26: GUARD POST TO RIM JOIST DETAIL, OPTION 1

MICHIGAN

Typical Deck Details

Based on the
2009 Michigan Residential Code
decks

OPTION 2: As shown in FIGURE 27, *hold-down anchors* must be installed to attach the rim joist to the deck joists. Hold-down anchors must be galvanized with 1.85 oz/sf of zinc (G-185 coating) or shall be stainless steel. There shall be a minimum of two bolts at the anchors' attachment to the joist. Look for model number HD2A in a Zmax coating from Simpson Strong-Tie, model number HD2A in a Triple Zinc coating from USP, or the hot-dipped galvanized DeckLok by Morse Technologies. Other hold-down anchor models meeting the minimum requirements may also be used.

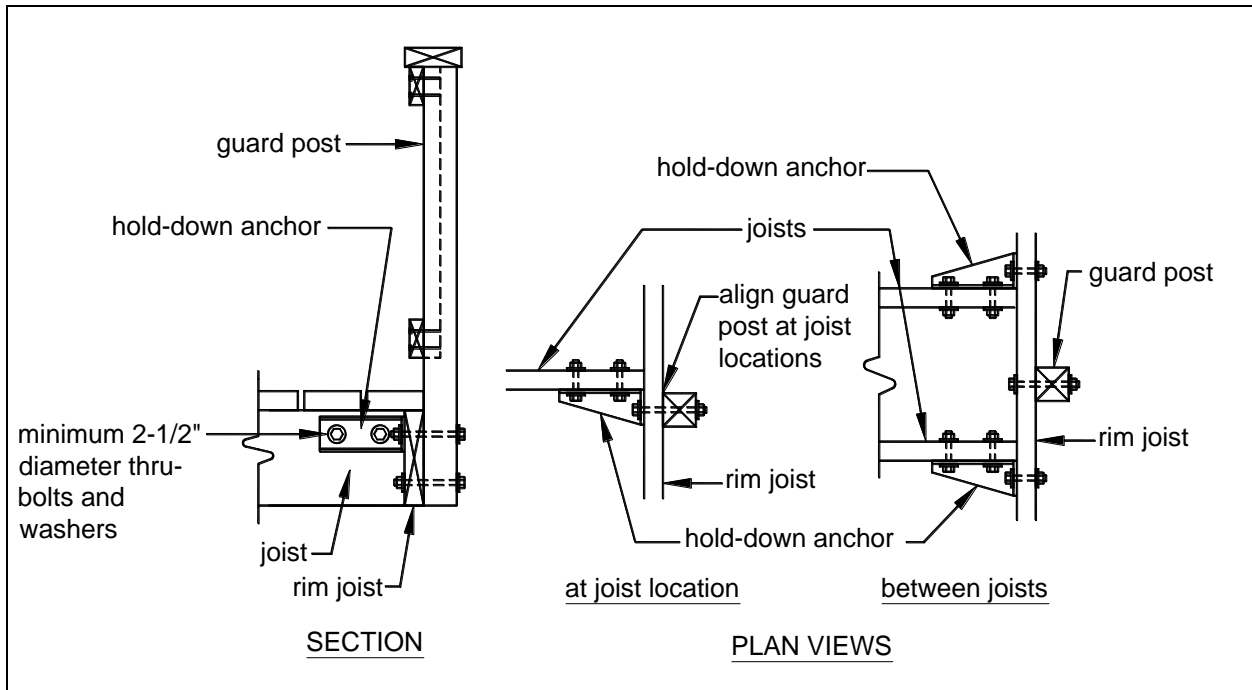

FIGURE 27: GUARD POST TO RIM JOIST DETAIL, OPTION 2

OPTION 3: As shown in FIGURE 28, the rim joist must be fastened to deck joists with two 20 gage *stud tie plates* attached per the manufacturer's instructions with hot-dipped galvanized or stainless steel fasteners. Stud tie plates must be galvanized with 1.85 oz/sf of zinc (G-185 coating) or shall be stainless steel. Look for model number SP1 in a Zmax coating from Simpson Strong-Tie or model number SPT22 in a Triple Zinc coating from USP. Other stud tie plate models meeting the minimum requirements may also be used.

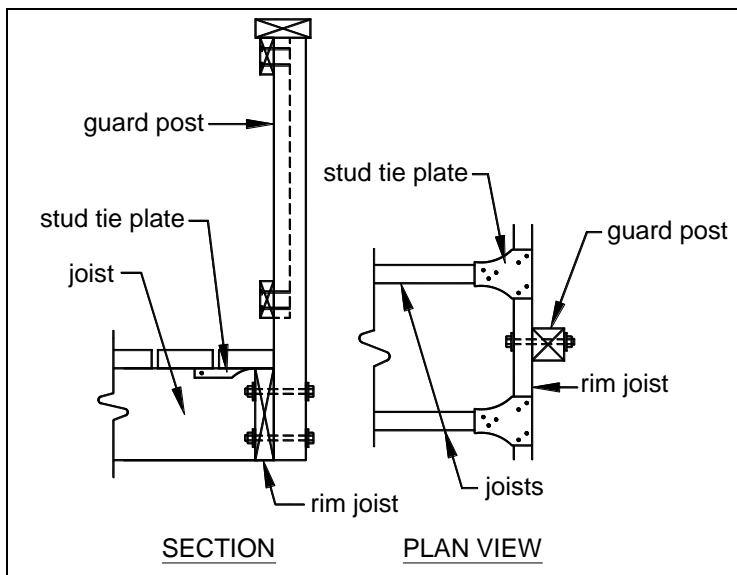

FIGURE 28: GUARD POST TO RIM JOIST DETAIL, OPTION 3

MICHIGAN

Typical Deck Details

Based on the
2009 Michigan Residential Code
decks

STAIR REQUIREMENTS

Stairs, stair stringers, and stair guard shall meet the requirements shown in FIGURE 29 through FIGURE 36. All stringers shall be 2x12. Stair stringers shall not span more than the dimensions shown in FIGURE 30. If the stringer span exceeds these dimensions, then an intermediate landing will be required. All intermediate stair landings must be designed and constructed as a free-standing deck using the details in this package.

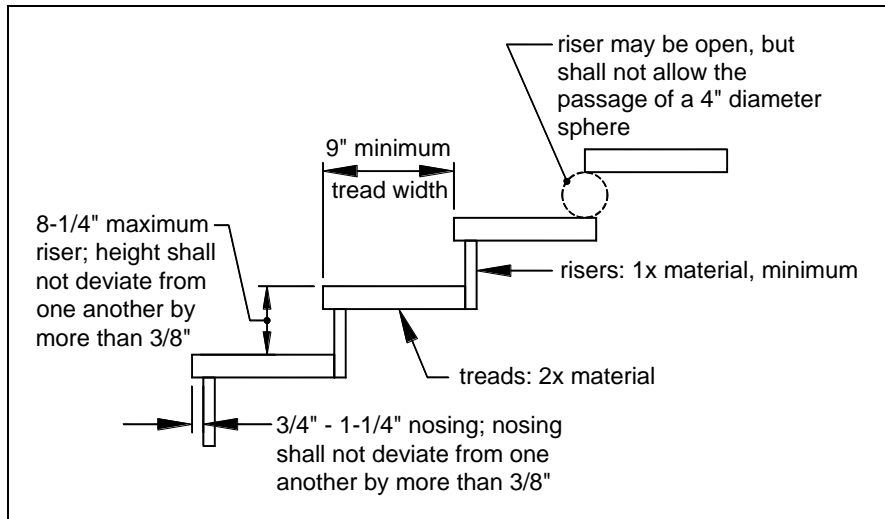

FIGURE 29: TREAD AND RISER DETAIL

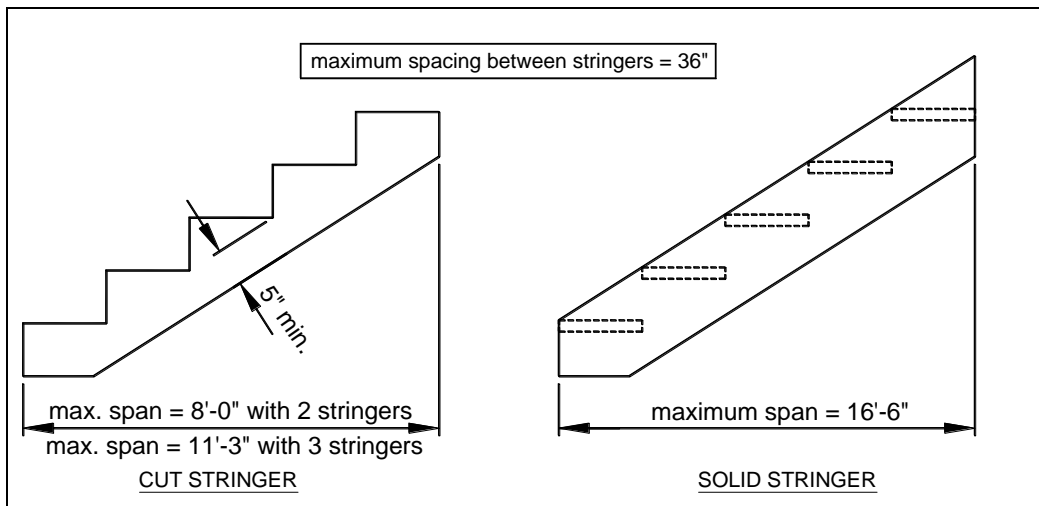

FIGURE 30: STAIR STRINGER REQUIREMENTS

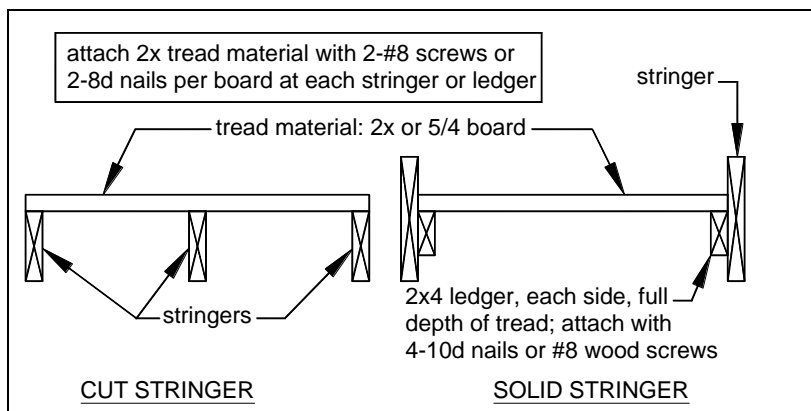

FIGURE 31: TREAD CONNECTION REQUIREMENTS

MICHIGAN

Typical Deck Details

Based on the
2009 Michigan Residential Code
decks

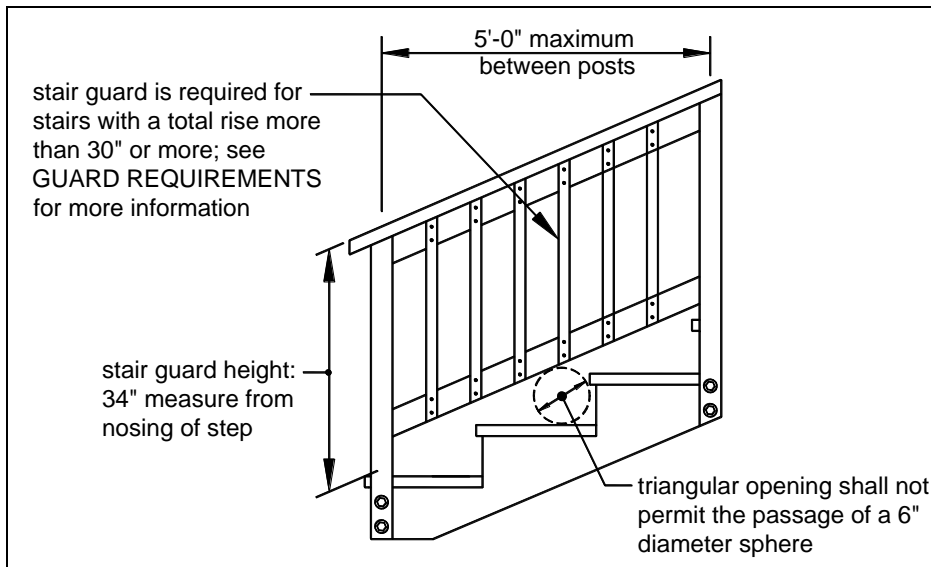

FIGURE 32: STAIR GUARD REQUIREMENTS

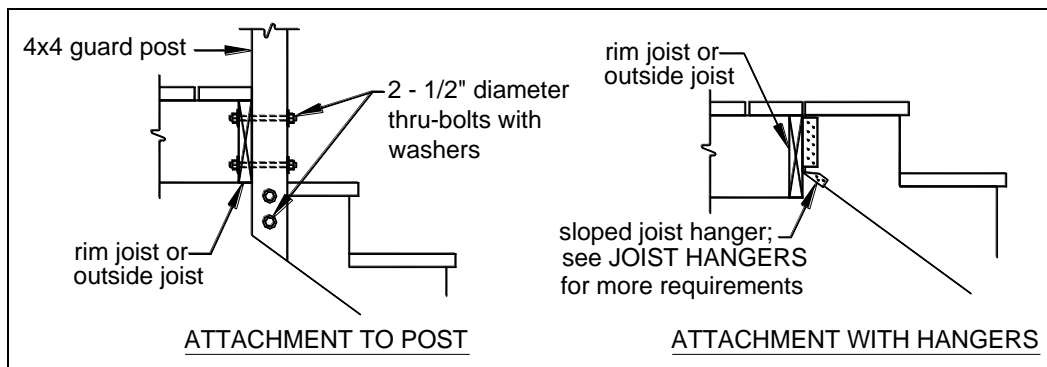

FIGURE 33: STAIR STRINGER ATTACHMENT DETAIL

STAIR HANDRAIL REQUIREMENTS

All stairs with 4 or more risers shall have a handrail on one side. See FIGURE 34. Handrails shall be graspable and shall be composed of decay-resistant and/or corrosion resistant material. The hand grip portion, if circular, shall be between 1-¹/₄" and 2-¹/₄" in diameter. Shapes other than circular shall have a perimeter dimension between 4" and 6-¹/₄" with a maximum cross sectional dimension of 2-¹/₄". All shapes shall have a smooth surface with no sharp corners. Handrails shall run continuously from a point directly over the lowest riser to a point directly over the highest riser and shall return to the guard at each end; see FIGURE 35. Handrails may be interrupted by guard posts only at a turn in the stair.

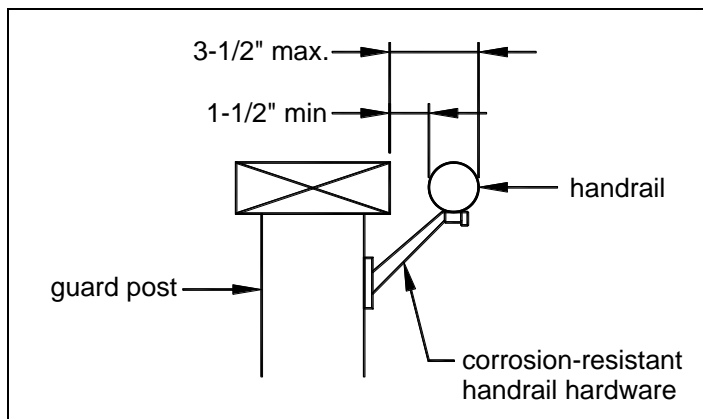

FIGURE 34: HANDRAIL REQUIREMENTS

MICHIGAN

Typical Deck Details

Based on the
2009 Michigan Residential Code
decks

STAIR FOOTING REQUIREMENTS

Where the stairway meets grade, attach the stringers to the stair guard posts as shown in FIGURE 36. Posts shall bear on footings below frost depth. Stringers shall not bear on new or existing concrete pads or patios that are not founded below frost depth. When guards are not required, see GUARD REQUIREMENTS on Sheet 12, posts may terminate below the bottom tread elevation.

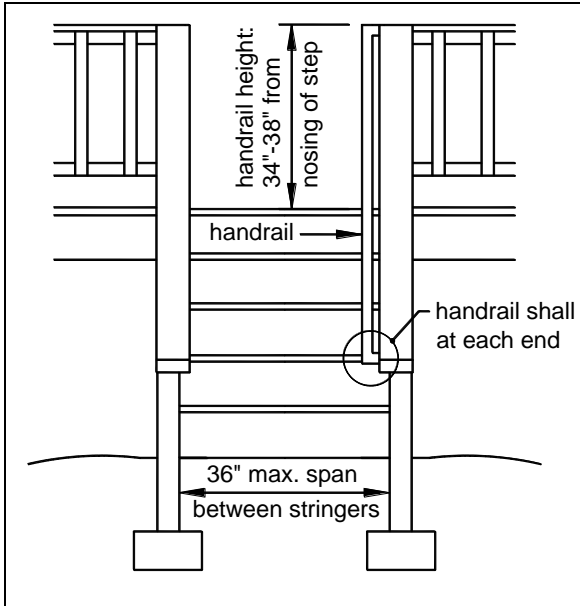

FIGURE 35: MISC. STAIR REQUIREMENTS

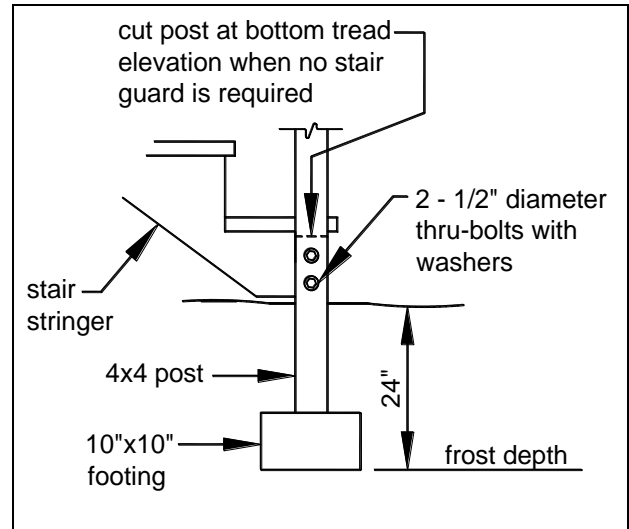

FIGURE 36: STAIR FOOTING DETAIL 42 inches deep not 24 inches

STAIR LIGHTING REQUIREMENTS

Stairways shall have a light source located at the top landing such that all stairs and landings are illuminated. The light switch shall be operated from inside the house. However, motion detected or timed switches are acceptable.

FRAMING AT CHIMNEY OR BAY WINDOW

All members at a chimney or bay window shall be framed in accordance with FIGURE 37. Headers may span a maximum of 6'-0". When a chimney or bay window is wider than 6'-0", one or more 6x6 posts may be added to reduce header spans to less than 6'-0". In such cases, the post footing must meet the requirements on Sheet 7. Headers with a span length greater than 6'-0" require a plan submission.

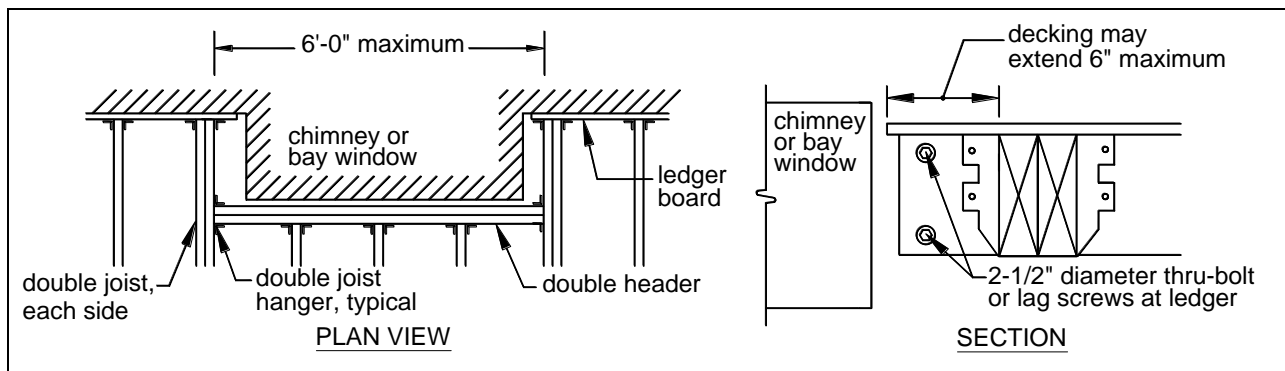

FIGURE 37: REQUIREMENTS FOR FRAMING AT CHIMNEY OR BAY WINDOW

MICHIGAN

Typical Deck Details

Based on the
2009 Michigan Residential Code
decks

PRODUCT SPECIFICATIONS

FastenMaster

www.fastenmaster.com

1-800-518-3569

Product referenced:

LedgerLok

Hilti

www.hilti.com

1-800-879-8000

Product referenced:

Epoxy anchor HY-20

Morse Technologies

www.mtdecklok.com

1-866-617-3325

Product referenced:

DeckLok (hot-dipped galvanized)

Ramset-Redhead

www.ramset-redhead.com

1-800-348-3231

Product referenced:

Epoxy anchor Epcon Acrylic 7

Simpson Strong-Tie

www.strongtie.com

1-800-999-5099

Products referenced (in Zmax coating):

Hurricane clips

Joist hangers

Hold-down anchors HD2A

Stud tie plates SP1

USP Structural Connectors

www.uspconnectors.com

1-800-328-5934

Products referenced (in Triple Zinc coating):

Hurricane clips

Joist hangers

Hold-down anchors HD2A

Stud tie plates SPT22

MICHIGAN

Typical Deck Details

Based on the
2009 Michigan Residential Code
decks